



VW BILLET DISTRIBUTOR INSTALLATION INSTRUCTIONS

LIMITED WARRANTY

PerTronix, Inc. warrants to the original Purchaser of its Flame-Thrower billet distributor that the product shall be free from defects in material and workmanship (normal wear and tear excluded) for a period of 12 months from the date of purchase.

If within the period of the foregoing warranty PerTronix finds, after inspection, that the product or any component thereof is defective, PerTronix will, at its option, repair such products or component or replace them with identical or similar parts PROVIDED that within such period Purchaser:

1. Promptly notifies PerTronix, in writing, of such defects.
2. Delivers the defective product or component to PerTronix (Attn: Warranty) with proof of purchase date; and
3. Has installed and used the product in a normal and proper manner, consistent with PerTronix printed instructions

THE FOREGOING LIMITED WARRANTY IS EXCLUSIVE AND IN LIEU OF ALL OTHER WARRANTIES, WHETHER EXPRESS OR IMPLIED, INCLUDING ANY IMPLIED WARRANTY OF MERCHANTABILITY OR FITNESS FOR A PARTICULAR PURPOSE.

THE FURNISHING OF A REPAIR OR REPLACEMENT COMPONENT OR COMPONENTS SHALL CONSTITUTE THE SOLE REMEDY OF PURCHASER AND THE SOLE LIABILITY OF PerTronix WHETHER ON WARRANTY, CONTRACT OR FOR NEGLIGENCE, AND IN NO EVENT WILL PerTronix BE LIABLE FOR MONEY DAMAGES WHETHER DIRECT OR CONSEQUENTIAL.



440 East Arrow Highway
San Dimas, CA 91773
909-599-5955
www.pertronix.com

GENERAL INFORMATION

1. **IMPORTANT:** Read all instructions before starting installation.
2. This distributor uses male style terminal posts which require female style spark plug wires.
2. Solid core spark plug wires **MUST NOT** be used.

DISTRIBUTOR REMOVAL

1. Turn over the engine until it is positioned at top dead center on a compression stroke.
2. Remove the distributor cap, and make sure that the rotor is pointing towards the first cylinder in the firing order.
3. Disconnect the battery negative (-) cable.
4. Disconnect all wires and hoses attached to the distributor.
5. Remove the distributor hold down bolt.
6. Remove the distributor and driveshaft spring.
7. Verify that the distributor driveshaft slot is perpendicular to the engine case seam. See figure A.
8. Check the original distributor for excessive wear, or potential problems.
9. Remove the distributor hold-down clamp from the original distributor for use with the billet distributor.

DISTRIBUTOR INSTALLATION

1. Install the original distributor hold-down clamp onto the billet distributor housing. The clamp should sit flat against the distributor collar.
2. Remove the Flame-Thrower billet distributor cap.
3. Turn the distributor drive tang so that it lines up with the distributor driveshaft slot.
4. Install the distributor driveshaft spring.
5. Set the distributor into the engine. The rotor should be pointing to the 5 o'clock position and the distributor hold-down should sit completely flat on the engine block.

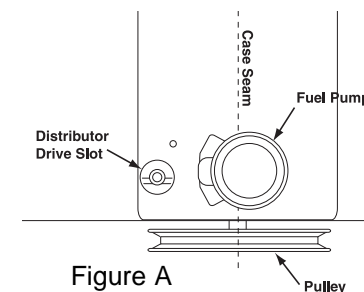

Figure A

6. Place the distributor cap onto the housing.
7. Turn the housing so that the terminal, that represents the first cylinder in the firing order, lines up with the rotor contact terminal.
8. Tighten the hold down and slightly tighten the distributor clamp. Once the ignition timing is adjusted the distributor clamp should be tightened completely.
9. Screw down the distributor cap and install the spark plug wires in the proper firing order. Beginning with the number one cylinder move clockwise 1 - 4 - 3 - 2.
9. Locate and remove the vacuum hose that was previously attached to the vacuum advance canister. Plug off the vacuum port.

WIRING

The Flame-Thrower billet distributor can be used in conjunction with most ignition coils rated at 0.6 ohms or greater. For optimum performance purchase and install a Flame-Thrower **II** high performance coil.

1. Many vehicles came equipped with ballast resistors or resistance wires. To achieve optimum performance we recommended removal of these components.
2. Determine the proper wire length, and attach the provided terminals. (Use a designated wire crimping tool to achieve an adequate connection)
3. Attach the **Red** wire to the coil positive terminal or a 12-volt ignition source.
4. Attach the **Black** wire to the coil negative terminal.
5. Check to insure correct polarity and that all connections are tight.
6. Reconnect the battery negative cable.

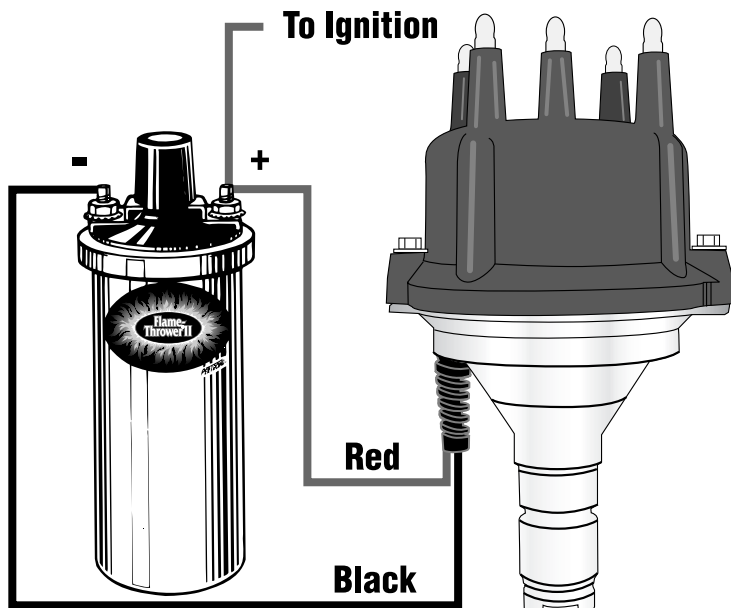

FINAL ADJUSTMENTS

1. Start the engine and set the initial timing.
2. Tighten the distributor clamp.

MECHANICAL ADVANCE ADJUSTMENTS

1. To adjust the mechanical advance curve, select the appropriate springs from the chart below. The Flame-Thrower billet distributor is factory equipped with the silver springs.
2. Remove the cap and rotor.
3. Remove the existing springs and install the desired springs.
4. Reinstall the rotor and cap.

	R. P. M.										
	500	1000	1500	2000	2500	3000	3500	4000	4500	5000	5500
Copper	0	5	16	24	24	24	24	24	24	24	24
Silver	0	0	3	10	16	22	24	24	24	24	24
Bronze	0	0	0	3	7	10	14	18	22	24	24

Crankshaft Degrees

The Flame-Thrower billet distributor comes with three different sets of advance limiters. These allow the maximum mechanical advance to be limited to 20, 16 or 12 degrees.

1. Choose the desired advance limit from the chart below.
2. Remove the distributor cap and rotor.
3. Remove the advance springs.
4. Install one advance limiter on each inner advance pin. (See Figure 1)
5. Reinstall the advance springs.
6. Reinstall the rotor and cap.
7. The advance limiters can be mixed resulting in unique variations of the original advance curve. When combined with mixed advance springs and limiters the mechanical advance can have a maximum of 78 different advance curves.

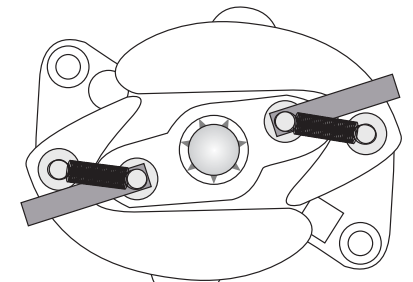
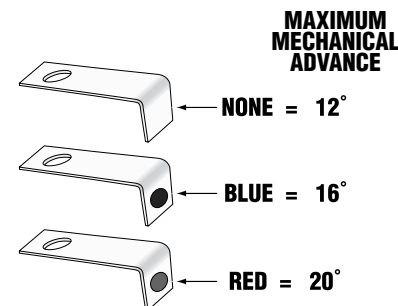

Figure 1