

TROUBLE SHOOTING TIPS

The Rev Limiter does not work.

Test for operation between each step.

- Check that all connections are correct. The black wire must be well grounded and to a clean contact or surface.
- Check to make sure the switches are in the correct position. Rotate the switches back and forth then back to the proper setting.
- Using a voltmeter set to 0-20 volts AC, place one lead of the meter to the white rev limiter wire, and the other lead to a good engine ground. Start the engine. The meter should read 2.5 volts with a tolerance of .2 volts.
- Swap the yellow and orange wire. Remember to isolate the unused wire.

My tachometer is inaccurate or doesn't work after installing the rev limiter.

Due to the accuracy of our Digital Rev Limiter, non-calibrated tachometers may not exactly match the rev limit. If the tachometer is grossly inaccurate, or does not operate at all, follow the steps below.

- Check that all connections are correct. The black wire must be well grounded and to a clean contact or surface.
- Locate the original tachometer trigger wire. Disconnect it from its current position and attach it to the rev limiter white wire.

LIMITED WARRANTY

PerTronix Inc. warrants to the original Purchaser of its Digital Rev Limiter product that the product shall be free from defects in material and workmanship (normal wear and tear excluded) for a period of 12 months from the date of purchase.

If within the period of the foregoing warranty PerTronix finds, after inspection, that the product or any component thereof is defective, PerTronix will, at its option, repair such product or component or replace them with an identical or similar product or component PROVIDED that within such period Purchaser:

1. Promptly notifies PerTronix, in writing, of such defects.
2. Delivers the defective product or component to PerTronix (Attn: Warranty) with proof of purchase date; and
3. Has installed and used the product in a normal and proper manner, consistent with PerTronix printed instructions.

THE FOREGOING LIMITED WARRANTY IS EXCLUSIVE AND IN LIEU OF ALL OTHER WARRANTIES, WHETHER EXPRESS OR IMPLIED, INCLUDING ANY IMPLIED WARRANTY OR MERCHANTABILITY OR FITNESS FOR A PARTICULAR PURPOSE.

THE FURNISHING OF A REPAIR OR REPLACEMENT COMPONENT OR COMPONENTS SHALL CONSTITUTE THE SOLE REMEDY OF PURCHASER AND THE SOLE LIABILITY OF PerTronix WHETHER ON WARRANTY, CONTRACT OR FOR NEGLIGENCE, AND IN NO EVENT WILL PerTronix BE LIABLE FOR MONEY DAMAGES WHETHER DIRECT OR CONSEQUENTIAL.

PERTRONIX PERFORMANCE PRODUCTS

440 East Arrow Highway
San Dimas, CA 91773
909-599-5955
www.pertronix.com

Digital REV Limiter

Installation Instructions

GENERAL INFORMATION

- Read all instructions before beginning installation
- The Digital Rev Limiter is for use on 4, 6 and 8 cylinder, even fire engines.
- Compatible systems include 12-volt negative ground, inductive type, single coil applications. (Not for use with Capacitive Discharge Systems)
- Disconnect the battery before installation.

MOUNTING INSTRUCTIONS

1. Choose a place to mount the rev limiter that is reasonably flat. Keep the rev limiter away from direct heat, excessive vibration and areas susceptible to wet conditions.
2. Position the rev limiter in the desired mounting position. Use the rev limiter as a template and mark the four mounting positions.
3. Choose the mounting hardware type that best suits your application.

Note: Sheet metal screws can be used when the back side of the mounting surface is not accessible. Machine screws should be used when both sides of the mounting surface are accessible.



#8 x 3/4 Sheet Metal Screw
Use a #31 drill bit (.120")
for screw hole.

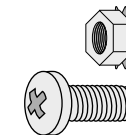

8-32 x 5/8 Machine Screw
Use a #29 drill bit (.136")
for screw hole.

WIRING THE DIGITAL REV LIMITER

There are two types of systems which the Digital Rev Limiter can be configured for. These are categorized as HEI and Non-HEI systems. HEI systems are defined as; Systems which have current limiting circuitry. Non-HEI systems include all other inductive type single coil ignitions. Determine which system you have and follow the corresponding wiring instructions. Remember to reconnect the battery after the installation is completed.

Non-HEI type systems. (FIGURE 1)

1. Attach the **BLACK** wire to a good engine ground. Make sure to remove any dirt or paint beforehand.
2. Attach the **RED** wire to a 12 volt power source controlled by the ignition switch.
3. Attach the **YELLOW** wire to the coil's negative terminal.
4. The **ORANGE** wire is not used for Non-HEI type systems. Use the provided end splice to isolate this wire.
5. The **WHITE** wire is a tachometer output, compatible with most modern tachometers.

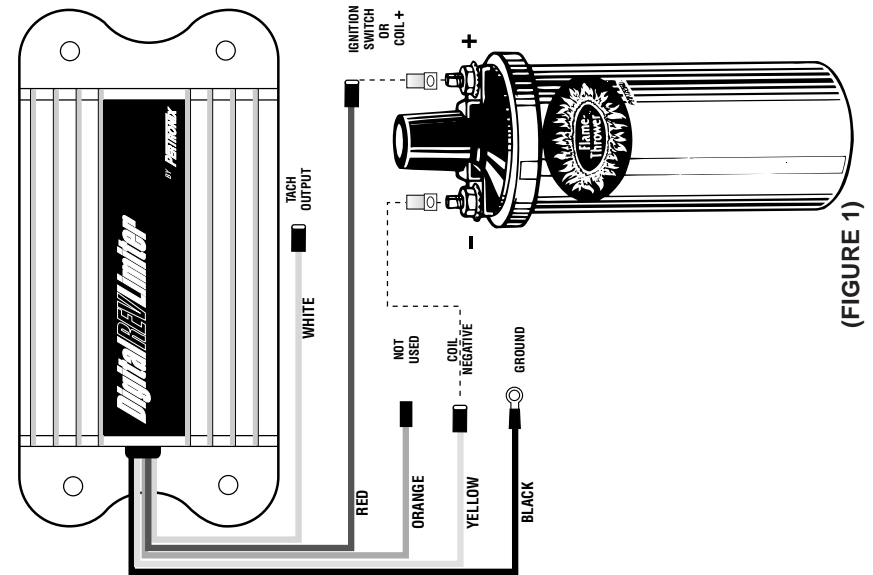

(FIGURE 1)

HEI type systems. (FIGURE 2)

1. Attach the **BLACK** wire to a good engine ground. Make sure to remove any dirt or paint before hand.
2. Attach the **RED** wire to a 12 volt power source controlled by the ignition switch. On GM HEI applications remove the original ignition switch wire from the terminal marked "BAT" on the coil cover. Plug the provided adapter harness onto this terminal and then reconnect the original ignition switch wire. Attach the **RED** wire to the open position on the adapter harness
3. Attach the **ORANGE** wire to the coil's negative terminal. On GM HEI applications plug the **ORANGE** wire onto the terminal marked "TACH" on the coil cover. If the terminal is currently used, remove the wire, plug the provided adapter harness onto the terminal and then reconnect the wire. Attach the **ORANGE** wire to the open position on the adapter harness.
4. The **YELLOW** wire is not used for HEI type systems. Use the provided end splice to isolate this wire.
5. The **WHITE** wire is a tachometer output, compatible with most modern tachometers.

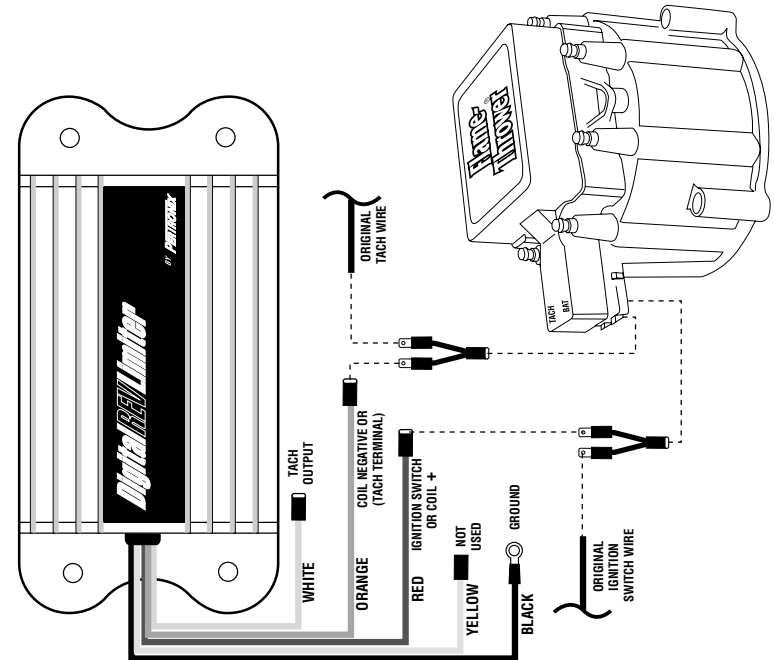

(FIGURE 2)

SETTING DIGITAL REV LIMITER

All settings can be done externally through the rotary switches on the front of the rev limiter. A white dot on the rotary portion of the switch indicates the switch position. Use a small flat blade screw driver to make adjustments.

1. Rotate the cylinder selection switch to the proper cylinder number for your application. The white dot on the face of the switch should point to the appropriate cylinder number. A slight indentation should be felt as the switch is turned. This signifies proper switch alignment. **Note:** The Digital Rev Limiter will only operate in 4, 6 and 8 cylinder modes.
2. The Digital Rev Limiter is not designed to be used as a governor. If the limit is set too low, and engine RPM is allowed to push up against the rev limit, failure to the Digital Rev Limiter or engine may result. Choose a desired rev limit. The Digital Rev Limiter has a 100 RPM resolution. This means that the rev limit can be set between 100 and 9900 in increments of 100 RPM. A typical limit would be 5500 RPM. In this case the 1000 switch is set to 5, and the 100 switch set to 5. By turning both switches to 0, the rev limiter is rendered non-operational.

